

Instructions for the Application Forms
FY2025 JSPS Postdoctoral Fellowship for Research in Japan
(Standard/Short-term Program(PE))

1. About the application in general

Applicants and candidates should check the application deadline set by the host institution as it may be a month or more before the submission date set by JSPS. The total number of application pages is 12, comprising Form 1 (4 pages), Form 2 (7 pages), and a Letter of Recommendation (1 page). Application forms will be printed in black-and-white when JSPS conducts its application screening.

Host institutions are to confirm whether the applicant (host researcher) is able to accept and take responsibility for the fellow throughout their tenure, especially when the applicant is not employed full-time or employed under a fixed-term contract or employed by an external funding source. The applicant must fulfill the obligations of a host researcher described on page 9 of the Application Guidelines after the candidate is awarded the fellowship. Application should not be made if the applicant knows at the time of submission that they will not be able to host the fellow during the full period of their tenure for such reasons as being scheduled to leave their position in the host institution or reaching retirement age.

2. Filling out Form 1 on the electronic application system

This form is filled out by the applicant (host researcher)

1) Language

Form 1 is to be written in Japanese or English. Note that some items on the English form require you to make entries in Japanese *furigana*. You may change the screen setting from Japanese to English and prepare the form in English; however, each field name on the PDF file, generated for your confirmation after you finish filling out the form, will appear in Japanese.

2) Restrictions

a) You cannot insert charts and images or draw underlines on Form 1. Nor is a selection of fonts available.

b) Note that the uploaded file size cannot be more than 3 MB. You may not be able to upload each file of Form 2 if the number of pages differs from that specified (7 pages for Form 2 and 1 page for the Letter of Recommendation).

In addition, you should upload files in ISO-standard A4 size (210 mm×297 mm), setting each page in portrait orientation. Be sure not to edit the file using PDF editor functions after you have converted your file into PDF format.

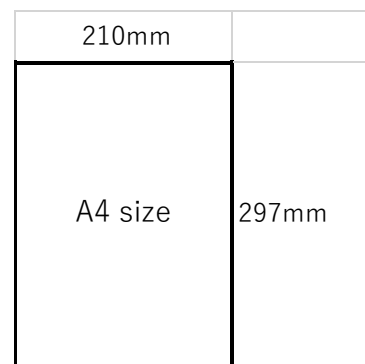

3) Notes on preparing the forms

Save data periodically when preparing the form as a session timeout may occur if you leave the system inactive for a period of time. As the information you are asked to give on the fellow (candidate) and the

recommender are the same as those on the first page (F1) of Form 2 prepared by the candidate (except the codes and *furigana* attached to the name of the recommender), you can input them efficiently by opening the Form 2 file first and copy & pasting the data on Form 1. Carefully check all the documents to confirm that the contents do not differ between Form 1, Form 2, and the Letter of Recommendation, including the name of the recommender, unless the candidate's name contains a mark such as umlaut or other exception.

You should fill out all required fields marked by an asterisk (*). You do not need to fill out fields that are not required. However, there are some items that require you to make entries in both English and Japanese. When a candidate has no current appointment, please still fill out "Current Appointment or Status" (though it's not a required field) in the manner described in the instruction points on page 3 so that the reviewers will not think you mistakenly left the space blank.

If there is an input error in Form 1, you will need to upload it again together with Form 2 and the Letter of Recommendation, even when you have already uploaded all of them. It is recommended, therefore, that you upload Form 2 and the Letter of Recommendation after you finish filling in all the fields of Form 1 and have checked it for mistakes.

4) Points on entering each field of Form 1

If you enter information incorrectly or fail to fill out required fields, an error message will be displayed. Correct the error according to the displayed message.

a) About "Basic Section Code," "Basic Section," "Document Review Section," and "Panel Review Section"

When preparing your application, select from the Review Section Table the review section in which you wish your application forms to be reviewed. In some cases, the same Basic Section topics are listed in plural Document Review Sections and/or "Panel Review Sections." So, be sure to carefully check the Review Section Table when choosing your review section.

Standard: https://www.jsps.go.jp/english/e-fellow/data/guideline_2025/2025_reviewsectionset_sta_e.pdf

Short-term: https://www.jsps.go.jp/english/e-fellow/data/guideline_2025/2025_reviewsectionset_short_e.pdf

b) Points requiring particular attention when filling in the fields for the applicant (host researcher)

"Department (English and Japanese)"

Type your official department name in the field "Department (English and Japanese)."

"Position"

Select from Professor, Associate Professor, Lecturer or Others. If you select "Others," type in your official title (this also applies to applicants who write in English).

"e-Rad Number"

** This number is entered if you apply for the standard program.*

Enter an e-Rad number if you have obtained one. The e-Rad number is used for administrative purposes to identify the applicant. Therefore, whether or not you have obtained an e-Rad number does not affect the screening process. If you have not obtained an e-Rad number, please enter "99999999" instead.

“Institution Information”

Enter information about your institution including the address of the department in which you (the applicant) have your position, not the address of the institution’s headquarters.

“Research Title”

Enter your research title concisely in up to 40 characters in Japanese or 100 letters in English. Each bracket and punctuation mark is counted as one letter. The space between words is counted as one letter in the case of English (example: ‘research activity’ is counted as 17 characters). Note that the research title you enter may not be changed even after the candidate is selected.

“Proposed Fellowship Tenure”

In one-month units, enter the starting date and the fellowship period. It is not necessary to enter the ending date. Application calls for the standard program are issued twice a year and for the short-term program three times a year. Check before applying as the starting dates of the programs vary in each recruitment round. Applicants should fully discuss the fellowship period with the candidate and, to the extent possible, not change it once the fellowship is awarded.

“Outline, significance and capability of cooperative research with the candidate”

Describe the capability of the applicant and the candidate to carry out the research, including the state of research achievements, funding acquisition and relevant international research and exchange activities.

c) Points requiring particular attention when filling in the fields for the fellow (candidate)

“Full Name”

Write in full the same name of the fellow (candidate) that appears in their passport. Enter the family name in uppercase letters. For the first and middle names, write each first letter in uppercase letter and use lowercase letters for the rest of the name. Type only in alphabetic letters and do not use letters with marks such as umlauts. If the fellow does not have a family name but has a first name, enter their first name in the family name field and leave the first name field blank.

“Nationality (Country/Region code)”

Enter the fellow’s corresponding country/region code referencing the List of Country/Region Codes. This also applies when entering the country in which the fellow’s affiliated institution and/or the institution where they received a doctoral degree is (are) located.

“Sex”

Select either "Male" or "Female". The information entered in this column will be used for data statistics and the international travel insurance application, but will not appear in the screening materials.

“Current Appointment”

Enter “PhD Student” in “Current Position or Status” if the candidate is a student enrolled in a doctoral course. If the candidate has no current affiliation or status, enter “N/A” in “Current Position or Status” and leave the “Institution,” “Department,” and “Country/Region” fields blank.

“Academic Degree” (PhD, or an equivalent)

Select either “Obtained” or “Expected.” Enter the anticipated award date (year, month, day) as close as possible if the candidate has not obtained a doctoral degree yet. If the day is unknown, enter the first day of the anticipated award month. Note that a person who holds a professional degree, such as a Japanese professional degree or a JD or MD in the United States, is not eligible to apply for this fellowship. (If the person also holds PhD degree, they are eligible to apply.)

It is recommended that the applicant seek, to the degree possible, confirmation at the time of application as to whether or not the candidate holds a PhD degree. A document certifying the candidate’s academic degree is not required when applying for the fellowship program. However, once candidates who hold a doctoral degree are selected for a Standard or Short-term Fellowship, they must submit either a copy of their PhD diploma or the original of their degree certificate before starting the fellowship.

Short-term fellows who are not scheduled to receive a degree before the fellowship starts (non-PhD holder) must submit one of the following: the original of a document certifying the date that a PhD degree is scheduled to be awarded, the original of a certificate of doctoral course enrollment, or a document written and signed by their supervisor confirming that they are scheduled to obtain a PhD degree within two years from the start of the fellowship.

Persons who fail to submit an above-stated document before the starting date will not be allowed to start their fellowship. Note that if a fellow does not start their research in Japan by the deadline specified by JSPS, their fellowship will be cancelled. Please refer to the “Postdoctoral Fellowships for Research in Japan Program Guidelines” for details on degree certification requirements.

https://www.jsp.go.jp/english/e-fellow/guideline_03.html

“Names of other Fellowship(s)”

Write within a maximum of 40 characters.

“Candidate Contact Information”

Select either “1. Office/Institute” or “2. Home”. Make sure to provide the candidate’s phone number and e-mail address. If there is no “postal code” in the candidate’s country/region, enter “99999.” If you choose “Office/Institute” for the candidate’s mailing address, enter the room number, name of their department and institution in the “Mailing Address” field.

“Name of Recommender”

Write the name of the recommender who signs the Letter of Recommendation, who is usually a person such as the candidate’s doctoral supervisor, but not the applicant. The recommender is only one person. If they do not have a family name but has a first name, enter the first name into the family name field and leave the first name field blank. If the recommender is Japanese, write their name in Japanese.

“Institution of Recommender”

Referring to the Institution Code List, enter the corresponding code number in the code field. If it is classified as “Others (99999),” type in the official name of the institution. If the recommender is employed at an overseas research institution, select “99999” and type in its official name.

“Justification to invite the candidate”

Charts and graphs cannot be inserted on the form nor can underlines be drawn. A selection of fonts is not available. It is recommended that you leave comfortable spacing between letters and lines so as to make your application easy to read during the screening process. It is also recommended that you check the writing and layout of the PDF file generated for your confirmation after filling out the form. Up to ten line breaks are permitted.

3. About Form 2

Candidates fill out Form 2 in English or Japanese using Word or PDF format. The candidate should themselves prepare Form 2 and submit it. If the contents of Form 2 are translated, it will not be accepted even if the original text was prepared by the candidate. Form 2 is prescribed by JSPS. Be sure to download the form for the FY2025 program from the JSPS website. Note that the candidates may not make any changes to the format of each field, including enlarging or reducing the frames, creating undesignated new fields, omitting fields or deleting notes, nor may the number of pages be changed. If an application is submitted using a format that differs from that of the specified year or program, or in which the form has been altered in style or format, JSPS will regard the application as defective. Note that the candidates should fill in all the fields except those in colored columns. To make it easy for the document reviewers to read, remember not to make the character spacing or width narrower than necessary. Selecting the font size 12 pt. or larger than 12 pt., Times New Roman Font to type the text, and Arial Font to create figures and tables are recommended when filling out Form 2. The “Signature” on the final page (F 7) of Form 2 should be the candidate’s own signature. It can be substituted with an e-signature or a PDF file of the original signature. The uploaded file size can be no more than 3 MB.

In addition, you should upload the file in ISO-standard A4 size (210 mm×297 mm), setting each page in portrait orientation. Be sure not to edit the file using PDF editor functions after you have converted your file into PDF format. See the SAMPLE on page 1.

4. Other points requiring particular attention when filling in the fields of Form 2

“Permanent Residency”

** For Short-term Program only*

If applicable, enter the name of the country in which you are a permanent resident. If not, leave the field blank.

“Current Appointment”

Enter “PhD student” in “Current Position or Status” if the candidate is a student in a doctoral course. If the candidate has no current affiliation or status, enter “N/A” in “Current Position or Status” and leave the “Institution,” “Department,” and “Country/Region” fields blank.

“Academic Degree”

Select either “Obtained” or “Expected.” Enter your anticipated award date (year, month, day) as close as possible if you have not been awarded a doctoral degree yet. If the day is unknown, enter the first day of the anticipated award month. Note that a person who holds a professional degree, such as a Japanese professional degree or a JD or MD in the United States, is not eligible to apply for this fellowship. (If the person also holds PhD degree, they are eligible to apply.) Select “PhD” or “Other.” If you select “Other,” enter the degree that is equivalent to a PhD in the adjacent space. The candidates may not start their fellowship if they fail to submit either a photocopy of their PhD diploma or their degree certificate by the starting date. However, it is not necessary to submit these documents at the time of application.

Short-term fellows who are not scheduled to receive a degree before the fellowship starts (non-PhD holder) must submit one of the following: a document certifying the date that a PhD degree is scheduled to be awarded, a certificate of doctoral course enrollment, or a document written and signed by their supervisor confirming that they are scheduled to obtain a PhD degree within two years from the start of the fellowship.

Note that if the candidate does not start the fellowship by the deadline specified by JSPS, their fellowship will be cancelled. Please refer to the “Postdoctoral Fellowships for Research in Japan Program Guidelines” for details on degree certification requirements.

https://www.jsps.go.jp/english/e-fellow/guideline_03.html

“Email Address 1”

Enter the email address at which the candidate can receive messages even after arriving in Japan.

“Letter of Reference/Recommendation”

Check whether the name of the recommender and their institution are the same as those contained in the Letter of Recommendation.

“Higher Education”

List all higher educational background including undergraduate and master's degrees. A candidate who is currently enrolled in a higher education institution should also fill in this field giving information about the institution.

“Previous Appointments”

A candidate who currently has an appointment should also fill in this field giving information about their current appointment.

“Language Ability”

Evaluate yourself (the candidate) on each item with a number from 5 to 1 indicating your language proficiency in Japanese and English. The larger the number, the higher the evaluation. If you use languages other than Japanese and English in your research, you may name up to three of them as well.

“List of Major Publications”

Excluding papers that are currently being peer reviewed or that have not yet been accepted for publication, list only papers that have been printed or accepted for publication.

Sample

(1) Peer reviewed published papers (including the papers published in bulletins and publications of collection of research papers) and books

- 1) 学振太郎、半蔵門花子、・・・ 「(題名)」、『(掲載誌名)』、〇〇出版、〇号、pp57-62、2006
- 2) 麴町次郎、学振太郎、・・・ 「(題名)」、『(掲載誌名)』、〇〇出版、〇号、pp33-39、2012

3) 半蔵門花子、麴町次郎、学振太郎 (6 番目)、〇〇〇〇、〇〇〇〇、〇〇〇〇、〇〇〇〇、〇〇〇〇、〇〇〇〇、〇〇〇〇、〇〇〇〇、〇〇〇〇、〇〇〇〇、〇〇〇〇、〇〇〇〇、〇〇〇〇、〇〇〇〇、〇〇〇〇、〇〇〇〇、〇〇〇〇、〇〇〇〇、〇〇〇〇、千代田三郎 (〇名省略)、 「(題名)」、 『(掲載誌名)』、〇〇出版、〇号、pp10-25、2014

他 5 報

1., 2., ...

Author(s) of article, 'title of journal article', title of journal, volume number, issue number, page number(s), year of publication

Around 20 authors can be listed at a maximum.

If you want to shorten the list, please follow the instructions below.

- ①The candidate and the first, second and last authors must be included in the authors' list.
- ②The name of the candidate should be underlined and given a rank within the authors' list.
- ③The above requirements do not apply to other authors.
- ④The order of authors should be the same as the publication.

If you cannot fill full data in the column, please enter the numbers omitted per each item.

(2) Other writings such as commentaries and reviews published in academic journals or magazines

- 1) 学振太郎・・・ 「(題名)」、 『(掲載誌名)』、〇〇出版、〇号、pp57-62、2009

1., 2., ...

Author(s) of article, 'title of journal article', title of journal, volume number, issue number, page number(s), year of publication.

【Papers scheduled for publication】

(1) List of peer reviewed and accepted papers to be published

- 1) 麴町治郎₁、学振太郎₂、・・・ 「(題名)」、 『(掲載誌名)』、〇〇出版、〇号、pp33-39、2025
- 1., 2., ...
Author(s) of article, 'title of journal article', title of journal, volume number, issue number, page number(s), year of publication.

Required Conditions for Candidates under this Fellowship

Please confirm that you meet all the written conditions. Check each box if you meet the conditions. You are not eligible to apply if you do not meet all of the conditions. Modifying the conditions is not allowed. If any of the conditions are modified on the application form, the application will be deemed falsified and rejected. If it becomes clear that the candidate does not meet the conditions after they are awarded the fellowship, the fellowship may be cancelled.

Sample (Standard)

20. Required Conditions for Candidates under this Fellowship Please confirm that you meet all of the below-stated conditions. Check each box if you meet the conditions You are not eligible to apply if you do not meet all the conditions.	
<input checked="" type="checkbox"/>	Checklist of Application Requirements
<input type="checkbox"/>	1. I do not have Japanese nationality/permanent residency. (If you are applying for or planning to obtain Japanese nationality/permanent residency, please note that the Fellowship will terminate on the day you acquire either of them.)
<input type="checkbox"/>	2. I have not received Fellowship(s) under the following programs in the past. (If you were awarded one or more of the following Fellowships but did not accept it/them, you are eligible to apply). a) JSPS Postdoctoral Fellowship for Research in Japan (Standard) b) JSPS Postdoctoral Fellowship for Research in Japan (Pathway)
<input type="checkbox"/>	3. I am not simultaneously applying for or planning to apply for the following JSPS programs, except in the case that an overseas nominating authority submitting my application. a) JSPS Postdoctoral Fellowship for Research in Japan (Standard), application submitted by a different Japanese host researcher and/or host institution. b) JSPS Invitation Fellowship (Long-term) c) JSPS Invitation Fellowship (Short-term)
<input checked="" type="checkbox"/>	4. I have read the above conditions and I meet all of them. I certify that the information provided in this application is true and correct.

For the conditions to which you can say “Yes,” put an X in the box.

5. About the Letter of Recommendation

Only one Letter of Recommendation is to be submitted, written by one person, such as the candidate’s doctoral supervisor, on one page. It may be written in either English or Japanese. It is preferable to write it on letterhead paper. The acceptable file format is Word or PDF. The letter of recommendation should be addressed to the applicant (host researcher) or the President of JSPS. The letter is to be signed by the recommender themselves. It can be substituted by an e-signature or a PDF file of the original signature. The applicant may not write the letter of recommendation. If the applicant is the candidate’s doctoral supervisor another person who is closely familiar with the candidate’s research, such as a faculty member who has conducted reviews of the candidate’s papers, should be asked to write the letter. The uploaded file size can be no more than 3 MB.

In addition, you should upload the file in ISO-standard A4 size (210 mm×297 mm), setting each page in portrait orientation. Be sure not to edit your files using the PDF editor functions after you have converted them into PDF format. See the SAMPLE on page 1.